

Improved lower bound for 2-identifying code in the square grid

Ville Junnila

Department of Mathematics

University of Turku

Finland

Preliminaries

- Let $G = (V, E)$ be a simple undirected graph.
- The ball of radius r centered at $u \in V$ is defined as

$$B_r(u) = \{v \in V \mid d(u, v) \leq r\}.$$

- A nonempty subset of V is called a *code*, and its elements are called *codewords*.
- Let $C \subseteq V$ be a code. Then for every $u \in V$ we denote

$$I_r(u) = I_r(C; u) = B_r(u) \cap C.$$

The set $I_r(u)$ is called the *I -set* of u .

Definition

Definition. A code $C \subseteq V$ is said to be r -*identifying* in G if the I -sets $I_r(u)$ are nonempty for all $u \in V$ and for all $u, v \in V (u \neq v)$

$$I_r(u) \neq I_r(v). \quad (1)$$

- This definition is due to Karpovsky, Chakrabarty and Levitin (1998).
- Let $X \subseteq V$ and $Y \subseteq V$. The *symmetric difference* of X and Y is defined as $X \Delta Y = (X \setminus Y) \cup (Y \setminus X)$.
- The condition (1) can be replaced by $I_r(u) \Delta I_r(v) \neq \emptyset$.
- If $I_r(u) \Delta I_r(v) \neq \emptyset$, then we say that u and v are r -separated by C .

Optimal code

- In studying identifying codes, the main goal is usually to find as small codes as possible.
- The smallest cardinality of an r -identifying code in a *finite* graph G is denoted by $M_r(G)$.
- An r -identifying code attaining the smallest cardinality is called *optimal*.
- In order to measure codes in *infinite* graphs such as grids, we later define the concept of *density*.

Square grid G_S

- The square grid G_S with the vertex set \mathbb{Z}^2 illustrated.

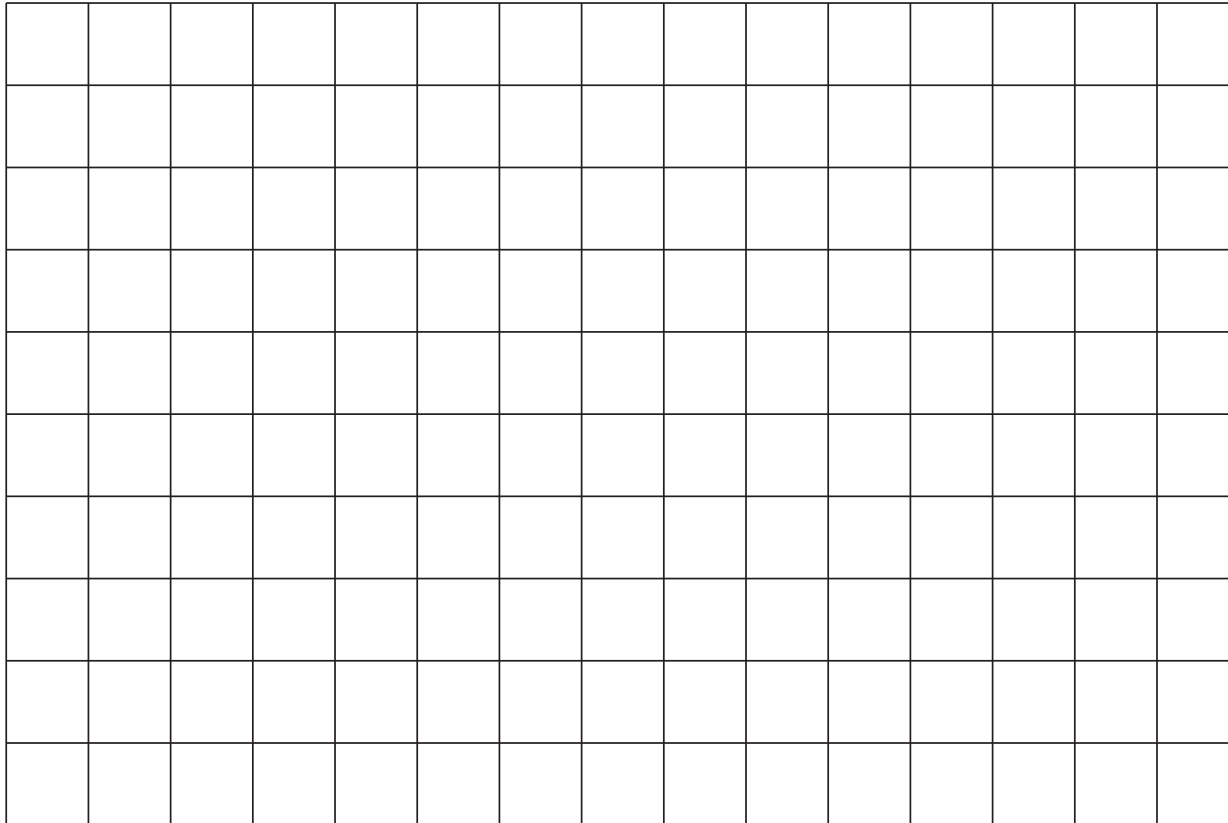

Density

- Consider the square grid G_S with the vertex set $V = \mathbb{Z}^2$.
- Define $Q_n = \{(x, y) \in \mathbb{Z}^2 \mid |x| \leq n, |y| \leq n\}$.
- In order to measure codes, we define the *density* of a code C in G_S as

$$D(C) = \limsup_{n \rightarrow \infty} \frac{|C \cap Q_n|}{|Q_n|}.$$

- An r -identifying code with the smallest density is called *optimal*. Moreover, this smallest density is denoted by $\delta_r(G_S)$.

Known results on G_S

- By Cohen *et al.* (1999), there exists a construction stating that $\delta_1(G_S) \leq 7/20$.
- Ben-Haim and Litsyn (2005) showed that

$$\delta_1(G_S) = 7/20.$$

- By Charon *et al.* (2001) and Honkala and Lobstein (2002) respectively provided the following lower and upper bounds for general r :

$$\frac{3}{8r} \leq \delta_r(G_S) \lesssim \frac{2}{5r}.$$

Construction in the case $r = 2$

- By Honkala and Lobstein (2002), we have the following 2-identifying code in G_S with density $5/29$.

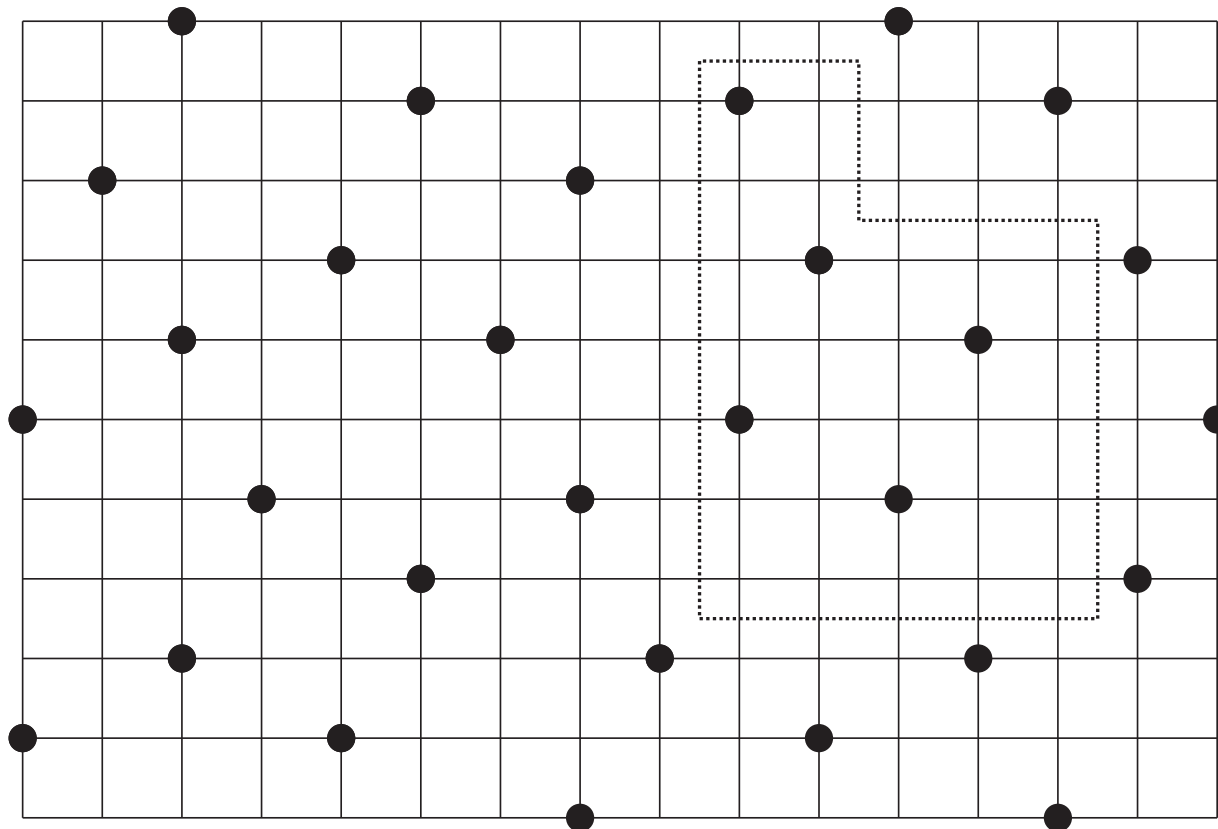

Lower bound in the case $r = 2$

- By the lower bound for general r , we have

$$\delta_2(G_S) \geq \frac{3}{20} = 0.15.$$

- Martin and Stanton (2010) improved this lower bound by showing that

$$\delta_2(G_S) \geq \frac{6}{37} \approx 0.162.$$

- We further improve this lower bound to $6/35$, i.e. show that

$$0.171 \approx \frac{6}{35} \leq \delta_2(G_S) \leq \frac{5}{29} \approx 0.172.$$

Share $s_r(c)$

- The *share* of a codeword $c \in C$ is a concept introduced by Slater (2001) and is defined as

$$s_r(c) = \sum_{u \in B_r(c)} \frac{1}{|I_r(u)|}.$$

- Example of the share:

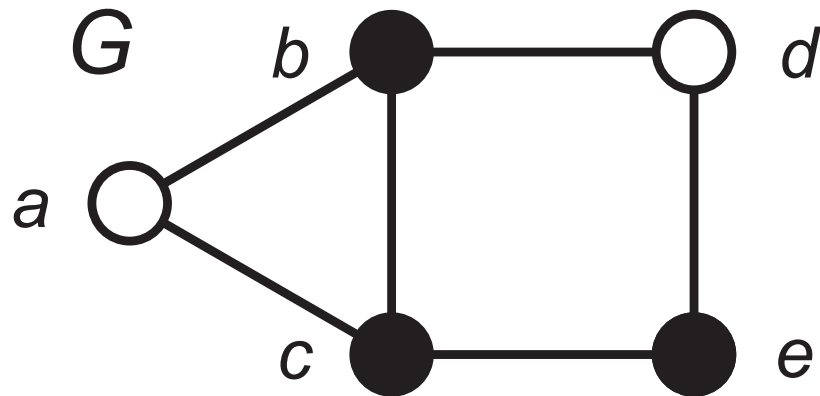

$$s_1(b) = \frac{1}{2} + \frac{1}{2} + \frac{1}{3} + \frac{1}{2} = \frac{11}{6}$$

$$s_1(c) = \frac{1}{2} + \frac{1}{2} + \frac{1}{3} + \frac{1}{2} = \frac{11}{6}$$

$$s_1(e) = \frac{1}{3} + \frac{1}{2} + \frac{1}{3} = \frac{4}{3}$$

The sum of shares

- Let $G = (V, E)$ be a finite graph and C be a code in G such that $I_r(u) \neq \emptyset$ for all $u \in V$.
- By double counting argument, we obtain that

$$\sum_{c \in C} s_r(c) = |V|.$$

- Proof by example:

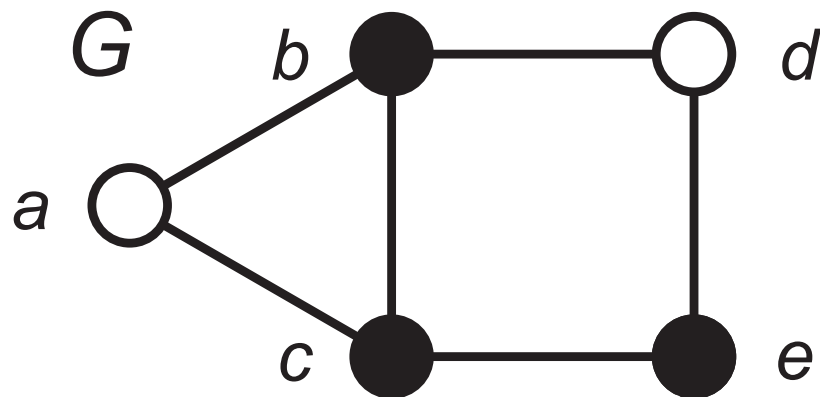

$$\begin{aligned} & s_1(b) + s_1(c) + s_1(e) \\ &= \frac{11}{6} + \frac{11}{6} + \frac{4}{3} = 5 \end{aligned}$$

Lower bounds using share

- Let $\alpha \in \mathbb{R}$ be such that $s_r(c) \leq \alpha$ for all $c \in C$.
- Then, by the previous slide, we have

$$|V| = \sum_{c \in C} s_r(c) \leq \alpha |C|.$$

- Hence, we have the lower bound $|C| \geq \frac{1}{\alpha} |V|$.
- If G is an infinite graph, then we have the following lower bound for the density of C :

$$D(C) \geq \frac{1}{\alpha}.$$

Share in G_S

- If C is a 2-identifying code in G_S , it is straightforward to show that $s_2(c) \leq 19/3$ for all $c \in C$.
- Hence, we obtain that $\delta_2(G_S) \geq 3/19 \approx 0.158$.
- To improve this lower bound, we need to introduce a *shifting scheme* (or discharging method) to even out the share.
- Indeed, we can show that on average $s_2(c) \leq 35/6$.
- This implies that the optimal density of a 2-identifying code in G_S satisfies

$$\delta_2(G_S) \geq \frac{6}{35} \approx 0.171.$$

How to approximate share

- Let u and v be adjacent codewords of a 2-identifying code.
- Since u and v are 2-separated by a codeword, at least one of the squared vertices is a codeword.

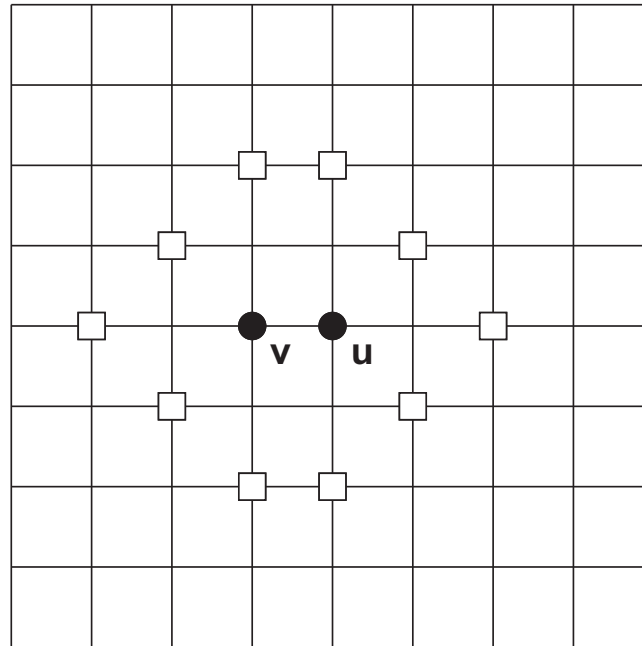

Example of approximation

- As an example, let us consider the following case:

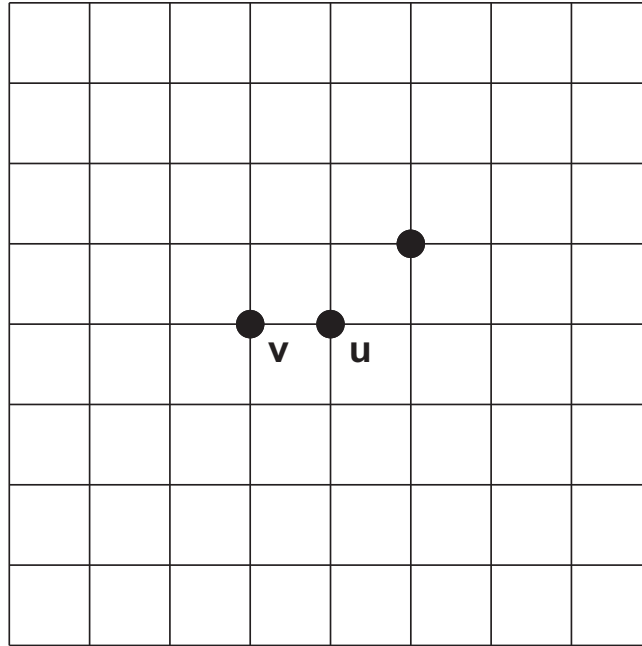

Example of approximation

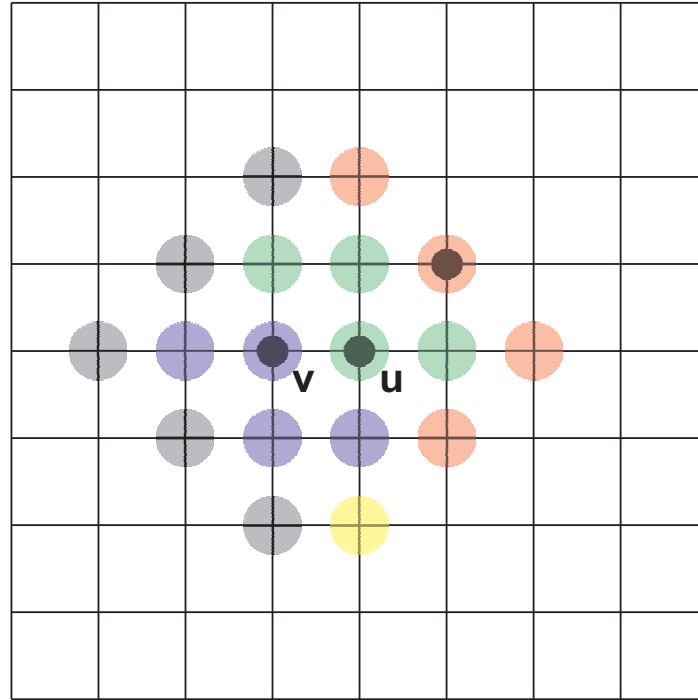

We have

$$s_2(\mathbf{u}) \leq \underbrace{\left(\frac{1}{2} + 3 \cdot \frac{1}{3}\right)}_{\text{red}} + \underbrace{\left(\frac{1}{2} + 3 \cdot \frac{1}{3}\right)}_{\text{blue}} + \underbrace{\left(\frac{1}{3} + 3 \cdot \frac{1}{4}\right)}_{\text{green}} + \underbrace{1}_{\text{yellow}} = \frac{61}{12}.$$

Example of approximation

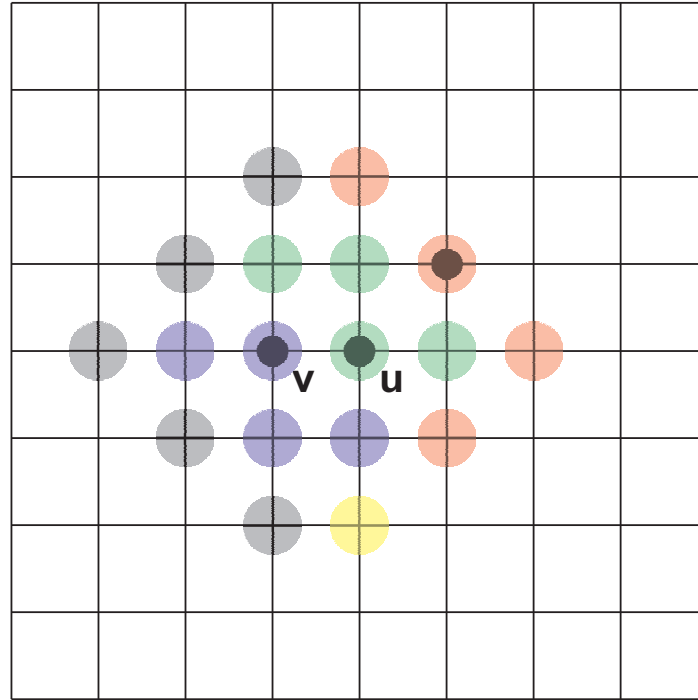

Similarly, we have

$$s_2(\mathbf{v}) \leq \underbrace{\left(\frac{1}{2} + 3 \cdot \frac{1}{3} \right)}_{\text{blue}} + \underbrace{\left(\frac{1}{3} + 3 \cdot \frac{1}{4} \right)}_{\text{green}} + \underbrace{\left(1 + 4 \cdot \frac{1}{2} \right)}_{\text{grey}} = \frac{67}{12}.$$

Example of approximation

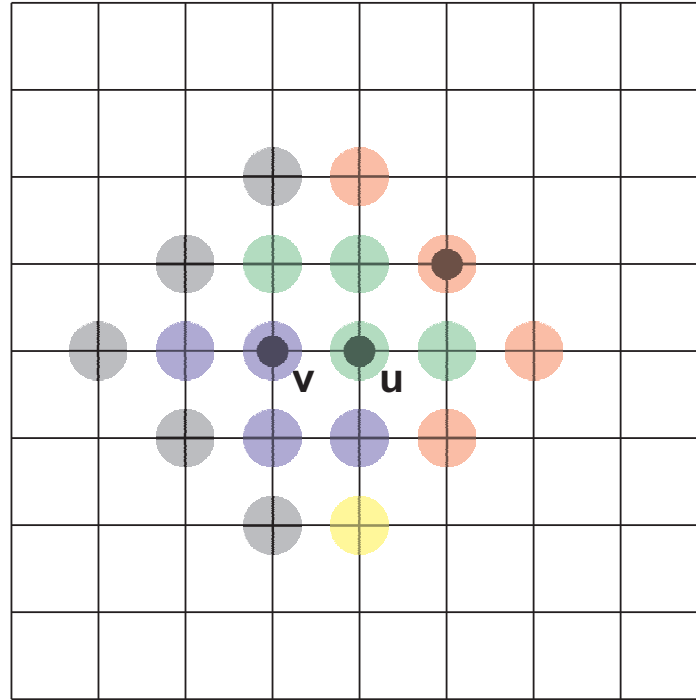

Together, we have

$$s_2(\mathbf{u}) \leq \frac{61}{12} = \frac{35}{6} - \frac{3}{4} \quad \text{and} \quad s_2(\mathbf{v}) \leq \frac{67}{12} = \frac{35}{6} - \frac{1}{4}.$$

What if $s_2(\mathbf{c}) > 35/6$?

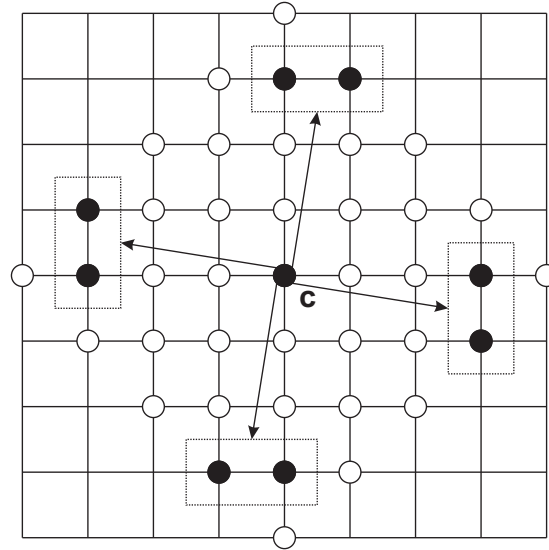

- We have $s_2(\mathbf{c}) = 19/3 > 35/6$.
- Shift $1/5$ units of share to each pair of codewords.
- After shifting, we have $s_2(\mathbf{c}) = 83/15 < 35/6$ and the shares of pairs of codewords stay low enough.

What if $s_2(\mathbf{c}) > 35/6$?

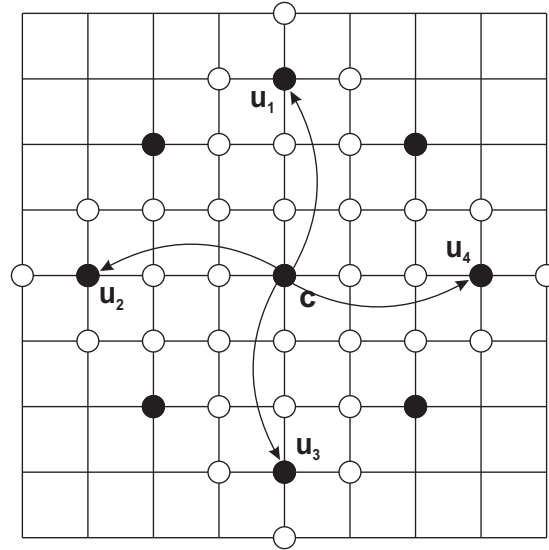

- We have $s_2(\mathbf{c}) = 6 > 35/6$.
- Shift $1/20$ units of share from \mathbf{c} to \mathbf{u}_i for $i = 1, 2, 3, 4$.
- After shifting, we have $s_2(\mathbf{c}) = 29/5 < 35/6$ and the shares of \mathbf{u}_i stay low enough.

The shifting scheme

There are in total 10 rules in the shifting scheme. The following facts can be shown:

- If $s_2(\mathbf{c}) > 35/6$ for some $\mathbf{c} \in C$, then at least $s_2(\mathbf{c}) - 35/6$ units of share is shifted from \mathbf{c} to other codewords.
- If share is shifted to a codeword $\mathbf{c} \in C$, then $s_2(\mathbf{c}) \leq 35/6$ and the codeword \mathbf{c} receives at most $35/6 - s_2(\mathbf{c})$ units of share.

In conclusion, after the shifting is done, the share of each codeword is at most $35/6$. Thus, we obtain the lower bound:

$$\delta_2(G_S) \geq \frac{6}{35} \approx 0.171.$$

Hexagonal grid G_H

- The infinite hexagonal grid G_H illustrated.

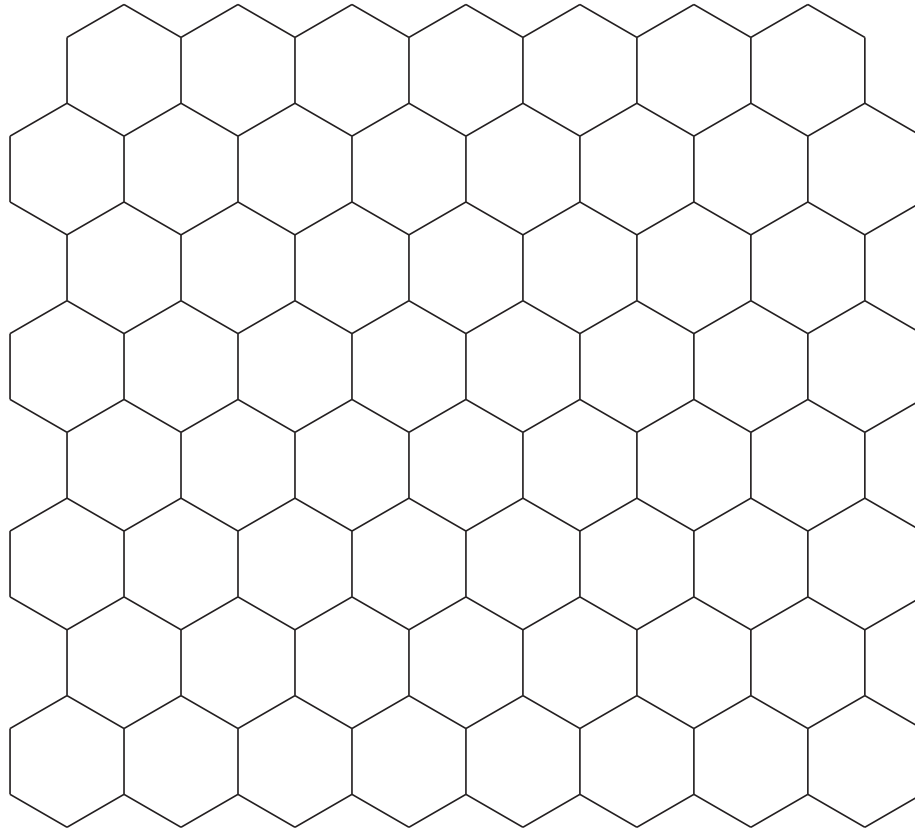

Known results on G_H

- By Cohen, Honkala, Lobstein and Zémor (2000), there exists a construction stating that $\delta_1(G_H) \leq 3/7 \approx 0.429$.
- Cranston and Yu (2009) proved a lower bound saying that $\delta_1(G_H) \geq 12/29 \approx 0.414$. Hence, we have

$$0.414 \lesssim \delta_1(G_H) \lesssim 0.429.$$

- Charon, Honkala, Hudry and Lobstein (2001) and Stanton (2011) respectively provided the following lower and upper bounds for general r :

$$\frac{2}{5r} \lesssim \delta_r(G_H) \lesssim \frac{5}{6r}.$$

Known results in the case $r = 2$

- Charon, Hudry and Lobstein (2002) provided a construction showing that $\delta_2(G_H) \leq 4/19 \approx 0.211$.
- Martin and Stanton (2010) proved the lower bound $\delta_2(G_H) \geq 1/5 = 0.2$.
- This also follows from the following easily shown fact stating that if C is a 2-identifying code in G_H , then $s_2(c) \leq 5$ for all $c \in C$.
- Moreover (in J. and Laihonen 2011), we have been able to show that on average the share of a codeword in G_H is at most $19/4$. Thus, we have

$$\delta_2(G_H) = \frac{4}{19}.$$

Thank you!